

6. L. A. Babenya, A. G. Goloveiko, V. I. Novikova, et al., "Effect of electrical fields on kinetics of phase transitions," *Inzh.-Fiz. Zh.*, 50, No. 5, 729-735 (1986).
7. A. G. Gagarin and V. Kh. Vigdorichik, "Convective heat exchange of a gas with a plane wall within the field of a corona discharge," *Elektron. Obrab. Mater.*, No. 2, 45-47 (1981).
8. I. B. Rubashov and Yu. S. Bortnikov, *Electrogas dynamics* [in Russian], Atomizdat, Moscow (1971).
9. G. Massy, *Negative Ions* [Russian translation], Mir, Moscow (1979).
10. R. Feynman, R. Layton, and M. Sands, *Feynman Lectures on Physics. Electricity and Magnetism* [Russian translation], Vol. 5, Mir, Moscow (1977).

HYDRODYNAMICS OF THE FILTRATION PROCESS OF DRYING

G. A. Aksel'rud, Ya. N. Khanyk,
and V. I. Topchii

UDC 66.047

The results of investigations and a capillary model of the hydrodynamics of the drying of gas-permeable sheet materials by filtration are presented.

The interest of investigators has recently been attracted by the process of drying of gas-permeable materials by filtration. The essence of this method is that the heat-transfer agent under the action of a pressure difference passes through pores and capillaries of the material, imparts heat to it, and, becoming saturated with moisture, is drawn out of it. As was established in [1-4], the filtration drying of gas-permeable materials occurs dozens of times more intensely than ordinary convective drying. The mechanism of filtration heat and mass exchange, as well as the factors causing its intensification, are described in detail in [5, 6].

In an investigation of filtration drying, it is important to study the hydrodynamics of the process. Filtration heat and mass exchange is a nonsteady process. The hydraulic resistance of a material in the process of drying is a variable quantity; it decreases from a maximum value at the start of drying, when the material has a moisture content $W = W_0$, to a minimum when the moisture content is $W = W_{eq}$.

The rate of filtration of the heat-transfer agent through the material increases with a decrease in its moisture content. The only constant hydrodynamic characteristic of the material is the dependence of the hydraulic resistance on the rate of air movement through the pores and capillaries, when the material is in a dry state.

To obtain the analytic dependence between the hydrodynamic parameters ΔP_m and Q_m of the material in the dry state and the current values ΔP and Q , varying in the process of drying, we present a capillary model below. The occurrence of both the mass-exchange and the hydromechanical processes has a very complicated character, and the proposed model reflects the true picture of these phenomena only in a first approximation.

The structure of a porous solid, all the capillaries of which are of cylindrical shape, pass through it, and are partly filled with moisture, is represented in simplified form in Fig. 1. If a heat-transfer agent moves through such a solid, then the current value of the hydraulic resistance, equal to $\Delta P = P_1 - P_2$, corresponds to a velocity of the heat-transfer agent of

$$\omega = \frac{4Q}{NF\pi d_c^2} \quad (1)$$

Lenin Komsomol Polytechnic Institute, Lvov. Translated from *Inzhenerno-Fizicheskii Zhurnal*, Vol. 50, No. 6, pp. 959-963, June, 1986. Original article submitted February 25, 1985.

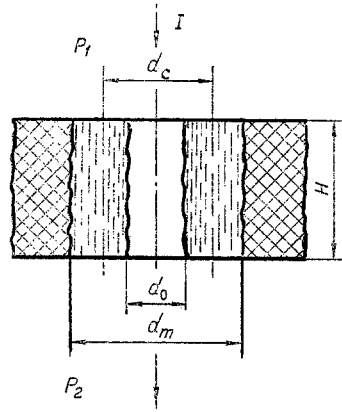

Fig. 1. Structure of a porous solid; I) heat-transfer agent.

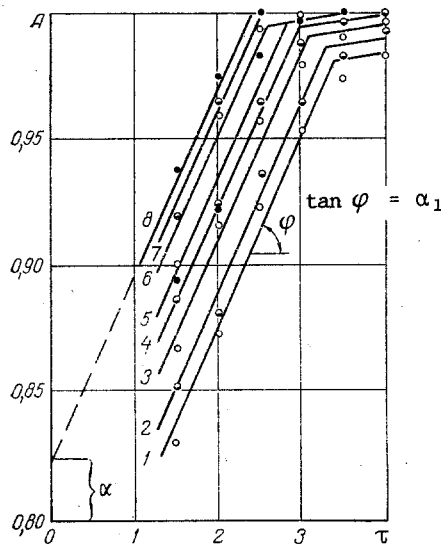

Fig. 2

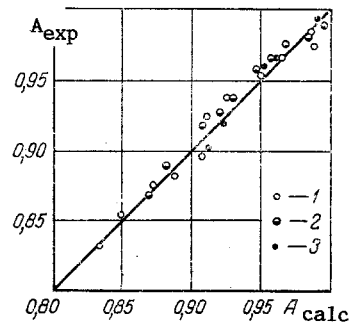

Fig. 3

Fig. 2. Dependence of A on τ according to the model presented: 1) $T_1 = 473^\circ\text{K}$ and $\Delta P_m = 0.5 \text{ kPa}$; 2) 473 and 0.7; 3) 573 and 0.5; 4) 573 and 0.7; 5) 473 and 1.6; 6) 673 and 0.5; 7) 673 and 0.7; 8) 573 and 1.6. τ , sec.

Fig. 3. Comparison of calculated and experimental values of A : 1) $T_1 = 473^\circ\text{K}$; 2) 573; 3) 673.

Intense evaporation of moisture occurs in the capillaries, accompanied by an increase in the capillary diameter d_c . The time variation of the moisture content of the material is described by the equation

$$-\frac{dW}{d\tau} = k\pi d_c H N F (\Pi_s - \Pi). \quad (2)$$

The moisture content of the material can be expressed by the function

$$W = \frac{N\pi(d_m^2 - d_c^2)\rho_w}{4\rho_m}. \quad (3)$$

Then

$$-\frac{dW}{d\tau} = k\pi d_c HF (\Pi_s - \Pi) N, \quad (4)$$

from which

$$\frac{d(d_c)}{d\tau} = 2kFH\Delta\Pi \frac{\rho_m}{\rho_w}. \quad (5)$$

After integration, we find that $d_c = d_0$ at $\tau = 0$, i.e.,

$$d_c = d_0 + 2kFH\Delta\Pi\tau \frac{\rho_m}{\rho_w}, \quad (6)$$

while $d_c = d_m$ at $\tau = \tau_e$,

$$d_m = d_0 + 2kFH\Delta\Pi\tau_e \frac{\rho_m}{\rho_w}. \quad (7)$$

From Eqs. (6) and (7) we find that

$$d_c = d_0 + (d_m - d_0) \frac{\tau}{\tau_e}. \quad (8)$$

The velocity of motion of the heat-transfer agent through the porous solid can be represented by the function [7]

$$w = \frac{\varepsilon^3}{(1-\varepsilon)^2} \psi \Delta P, \quad (9)$$

$$\frac{\varepsilon^3}{(1-\varepsilon)^2} = k_f, \quad (10)$$

$$\varepsilon = \frac{\pi d_c^2}{4} N. \quad (11)$$

For a moist porous solid, ε varies with time in the process of drying, but for any current state we can write

$$\frac{\pi d_0^2}{4} N < \varepsilon < \frac{\pi d_m^2}{4} N. \quad (12)$$

From Eqs. (1), (8), and (9) it follows that the volumetric flow rate of heat-transfer agent passing through the porous solid is

$$Q = k_f \Delta P \psi N F \frac{\pi}{4} \left[d_0 + (d_m - d_0) \frac{\tau}{\tau_e} \right]^2. \quad (13)$$

At $\tau = \tau_e$,

$$Q_m = k_{f_m} \psi \Delta P_m N F \frac{\pi}{4} d_m^2. \quad (14)$$

Within the limits of variation of the porosity of the material $\varepsilon = 0.1-0.75$, the quantity $\varepsilon^3/(1-\varepsilon)^2$ is proportional to ε^4 . Then

$$\frac{k_f}{k_{fm}} = \left[\frac{d_0}{d_m} + \left(1 - \frac{d_0}{d_m} \right) \frac{\tau}{\tau_e} \right]^8. \quad (15)$$

Analyzing Eqs. (13), (14), and (15), we obtain

$$\frac{Q}{Q_m} = \frac{\Delta P}{\Delta P_m} \left[\frac{d_0}{d_m} + \left(1 - \frac{d_0}{d_m} \right) \frac{\tau}{\tau_e} \right]^{10}. \quad (16)$$

We assume that

$$\frac{d_0}{d_m} = \alpha. \quad (17)$$

Then

$$\sqrt[10]{\frac{Q}{Q_m} \frac{\Delta P_m}{\Delta P}} = \alpha + \left(\frac{1 - \alpha}{\tau_e} \right) \tau. \quad (18)$$

Designating the expression on the left side of Eq. (18) as A, we finally have

$$A = \alpha + \left(\frac{1 - \alpha}{\tau_e} \right) \tau. \quad (19)$$

In the coordinates A- τ , Eq. (19) is represented by a straight line not passing through the origin of coordinates, the tangent of the slope angle of which is $\tan \varphi = 1 - \alpha/\tau_e = \alpha_1$.

To verify the function (19), we investigated the time variation of ΔP and Q at different temperatures of the heat-transfer agent and initial pressure drops over the dry material. The tests with moist material, for which we took filtering cardboard, were carried out in the intervals of $T_1 = 473-673^\circ\text{K}$ and $\Delta P_m = 500-1600$ Pa. The results of the research are presented in Fig. 2, from which it is seen that the experimental data agree well with the theoretical data. Within the limits of variation of the moisture content of from $W_0 = 3.76$ kg/kg to $W_1 = 0.67$ kg/kg the treatment of the experimental results yields a linear function described by Eq. (19). At a moisture content of the material below $W_1 = 0.67$ kg/kg the slope angle of the straight line changes.

The character of the functions in Fig. 2, obtained by treating the experimental data in accordance with Eq. (19), can be explained as follows. At the start of the drying process in through capillaries, the intense evaporation of moisture occurs along with its partial mechanical evacuation. The increase in the value of A is connected with the variation of the diameter d_c from d_0 , when the capillaries are filled with moisture, to d_m , when they are free of moisture. The bend in the straight lines with the formation of a second section is explained by the fact that during the further drying after the removal of the capillary moisture, the absorptively bound moisture is evaporated osmotically from the intercapillary sections of the material, which makes it shrink. The variation of A in the second section of the straight lines is explained by the additional increase in d_c through shrinkage phenomena (the slope angle of the straight lines in the second section is considerably less than in the first section). According to the commercial requirements, the investigated material must dry by filtration from $W_0 = 4.0$ kg/kg to $W_1 = 0.67$ kg/kg, i.e., in the interval of variation of the moisture content falling on the first section of the straight lines.

Through the treatment of the experimental data, it was established that the value of α depends both on the temperature of the heat-transfer agent and on the pressure drop over the dry material, while the quantity α_1 is constant for all the drying regimes. The quantity α was obtained as a function of the rate of filtration of the heat-transfer agent through the dry material and the temperature of the drying agent. Thus, we have

$$A = 0.427 - 0.134 \frac{T_1}{T_0} + 1.036 \cdot 10^{-5} \text{Re} + 7.718 \cdot 10^{-2} \tau. \quad (20)$$

In Fig. 3 the values of A calculated from Eq. (20) are compared with the data calculated from Eq. (18). It is seen that the proposed capillary model agrees well with the test data in the interval of variation of the moisture content from $W_0 = 3.76$ kg/kg to $W_1 = 0.67$ kg/kg, and it makes it possible to calculate the current values of ΔP and Q with time and as a function of the initial hydrodynamic parameters of the material in the dry state.

NOTATION

Q , current value of the flow rate of the heat-transfer agent, m^3/sec ; Q_m , flow rate of the heat-transfer agent through the dry material, m^3/sec ; ΔP , current value of the hydraulic resistance of the material, Pa; ΔP_m , hydraulic resistance of the dry material, Pa; d_c , current value of the diameter of a capillary, m; d_0 , minimum diameter of a capillary, m; d_m , diameter of a capillary free of moisture, m; N , number of through capillaries per unit surface area of the material, $1/\text{m}^2$; W , moisture content of the material, kg/kg; H , thickness of the material, m; F , geometrical surface area of the specimen, m^2 ; ϵ , porosity of the material; ρ_m , density of the dry material, kg/m^3 ; ρ_w , density of water, kg/m^3 ; Π , water vapor pressure in the air, Pa; Π_s , pressure of saturated water vapor under the given drying conditions, Pa; $\Delta \Pi = \Pi_s - \Pi$; τ_e , total drying time, sec; τ , current drying time, sec; w , velocity of motion of the heat-transfer agent, m/sec; T_1 , temperature of the heat-transfer agent, $^\circ\text{K}$; $T_0 = 273^\circ\text{K}$; P_1 , pressure of the heat-transfer agent ahead of the material, Pa; P_2 , pressure of the heat-transfer agent after filtration through the material, Pa; ψ , proportionality factor; k , evaporation coefficient, $1/N \cdot \text{sec}$; Re , Reynolds number.

LITERATURE CITED

1. G. A. Aksel'rud, A. I. Chernyavskii, and Ya. N. Khanyk, "Drying of materials by filtration of a heat-transfer agent," *Inzh.-Fiz. Zh.*, **34**, No. 2, 230-235 (1978).
2. Ya. N. Khanyk and A. I. Chernyavskii, "Peculiarities of filtration drying," *Dokl. Nauchn. Soobshch. Lvov. Politekh. Inst.*, No. 3, 136-137 (1974).
3. I. F. Pikus, "Problems of intensification of the process of drying foam rubber," in: Abstracts of Papers of the Third Republic Conference on Increasing the Efficiency and Refinement of Processes and Apparatus [in Russian], *Izd. Akad. Nauk Ukr. SSR, Lvov* (1973) p. 205.
4. I. F. Pikus and M. A. Kucheryavyi, "An installation for drying gas-permeable porous articles," *USSR Inventor's Certificate No. 390,341, Byull. Izobret.*, No. 30 (1973).
5. Ya. N. Khanyk, "Drying of gas-permeable materials by filtration," *Author's Abstract of Candidate's Dissertation, Engineering Sciences, Kiev* (1980).
6. V. A. Zhuzhikov, *Filtration [in Russian]*, *Khimiya, Moscow* (1971).
7. M. É. Aéroov, O. M. Todes, and D. A. Narinskii, *Apparatus Containing Stationary Granular Beds [Russian translation]*, *Khimiya, Moscow* (1979).